

# Flipper CT

Small Piece Stacker/Folder-Stacker

CHICAGO®



## FLIPS, FOLDS, COUNTS AND STACKS

The Flipper CT is a simple, high-speed, labor saving folder/stacker with built-in discharge conveyor for the automatic counting and stacking of flat or half-folded small articles such as wash cloths, wiper cloths, shop towels and bar wipes. It is designed to automate the folding and stacking process to assure accurate counts, consistent quality and continuous high production—cycle times up to 1800 PPH on wash cloths. The CHI•Touch PC-based control allows for precise fold and stack adjustments and shows item description with both stack and total piece counts.

## Dimensions

### NOTE:

1. Specifications subject to change without notice. Consult factory for certified construction floor plan.
2. Millimeter dimensions are in [ ].
3. All dimensions are +/- 1/2".
4. Utility connections are located as shown.

CONNECTION(S)	DIA.	HEIGHT
(A) Air Connection	1/2"	8-1/2" [216]
(E) Electrical Connection	-	7-1/2" [191]

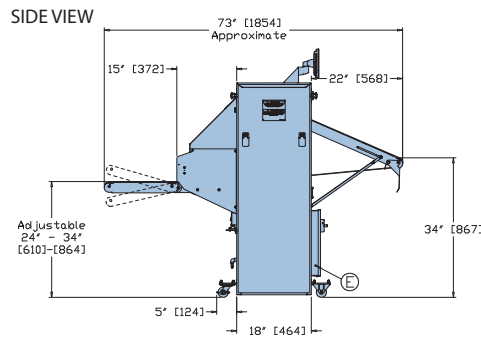

TOP VIEW

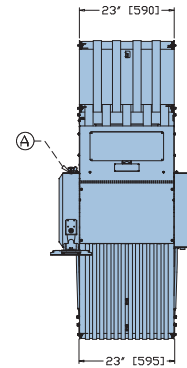

FRONT VIEW

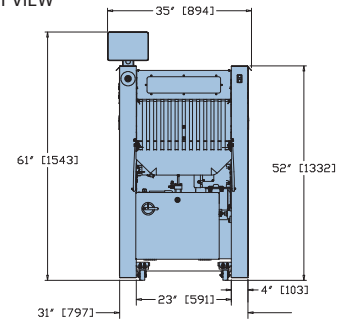

## Description

Flipper's small piece automation increases operator output by eliminating manual item counting, reducing fatigue and creating uniform bundles for efficient storing or packaging. Such automation makes production more consistent per operator hour. The standard auto-bypass table prevents overfeeding and resulting jams. Flipper's reverse pinch conveyor, with air assist

folding mechanism, is built into its inlet conveyor to enable larger articles, up to 24" long, to be half folded prior to counting and stacking. Complete stacks are automatically discharged to the integrated delivery conveyor for manual removal, or advanced directly onto an automated master conveyor. An optional return-operator conveyor is also available (shown on cover).

## Features

**Operation:** Individual item types are programmed for choice of flat stacking or folding, stack height and specific count. Articles are manually fed, precision measured by microprocessor control, and placed accurately on top of each other to form a stack. Completed stacks are conveyed to a convenient height for easy operator removal or can be discharged to a master conveyor system.

**Capacity:** Flipper will accept articles up to 24" long for folding and up to 12" long for flat stacking. Maximum size articles of 20" W x 24" L are folded in half by air pulse through reversing conveyor before being stacked onto the exit conveyor. Between 5 and 50 pieces can be stacked per bundle depending upon item thickness.

**Utility:** Flipper operates on 120 VAC and requires only compressed air supply. Flipper may also be connected to a production data accumulation system for automatic recording and storage of production and efficiency information.

**Safety:** Safety guards and panels for operator safety.

Visit Chicago's website [www.chidry.com](http://www.chidry.com) for easy access to the latest floorplans, technical specifications, etc.

## A Complete Range of Separating, Feeding, Ironing, Folding, and Sorting Options

Because Chicago specializes only in flatwork finishing equipment, it can offer the world's widest range of high production separating, feeding, ironing, folding and sorting equipment. Complete flatwork finishing systems range from automated multi-roll systems producing over 2000 pounds per hour, to compact ironers for small on-premise laundries.

Chicago's performance record is unmatched in tens of thousands of installations in commercial, hospitality, health care, textile rental, and institutional laundries. An experienced Chicago professional will be pleased to make an objective equipment recommendation based on your production,

space, utility and budget requirements. All equipment is designed and built in Chicago for complete quality control and prompt service and parts availability, including overnight delivery if necessary.

Contact your local Chicago distributor or the factory sales assistance office for a no-obligation analysis of your needs. Visit our newly redesigned and now mobile-friendly website [www.chidry.com](http://www.chidry.com) for easy access to current product brochures, detailed floor plans, and specifications, as well as videos of select Chicago products in action.



**CHICAGO DRYER COMPANY**  
2200 North Pulaski Road  
Chicago, Illinois 60639-3737 USA

Phone • 773.235.4430  
Fax • 773.235.4439  
Web • [www.chidry.com](http://www.chidry.com)  
Email • [chicago@chidry.com](mailto:chicago@chidry.com)

Bulletin #7588